

eveningbr^eeze

Handbook

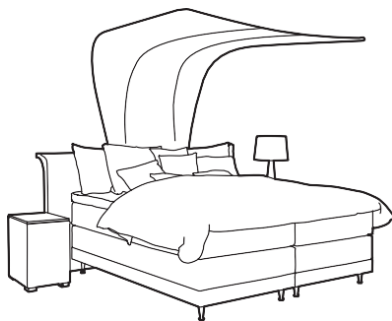

eveningbre^eze

Strabrecht 4
5591 BP Heeze
the Netherlands

www.evening-breeze.com
info@evening-breeze.com

Contents

1	Introduction	p. 6
2	General Information	p. 7
	2.1 Your Package Should Contain	p. 8
	2.2 Product Specifications	p. 9
	2.3 Dimensions	p. 10
3	Installation - Cooling System	p. 13
	3.1 Refrigerant R-410A Information	p. 14
	3.2 Precautions & General Information	p. 15
	3.3 Needed Tools	p. 18
	3.4 Unpacking	p. 18
	3.5 Location	p. 20
	3.6 Hole Placement	p. 24
	3.7 Piping Connections	p. 26
	3.8 System Pressurization	p. 30
	3.9 Wrapping Valves & Pipes	p. 33
	3.10 Ductwork	p. 34
	3.11 Drainage	p. 35
	3.12 Electronics	p. 36
	3.13 Wiring Diagrams	p. 39
4	Installation - Ventilation System	p. 41
	4.1 Bed Requirements & Placement	p. 41
	4.2 Ventilation System	p. 42
5	Maintenance	p. 45
	5.1 Regular Tasks	p. 46
	5.2 Cleaning the Air Filter	p. 46
	5.3 Cleaning the Evaporator Coil	p. 47
	5.4 Cleaning the Ventilation System	p. 48
	5.5 Vacuum Cleaning the Outdoor Unit Coil	p. 49

5.6	Disinfecting the Outdoor Unit Coil	p. 50
5.7	Pump Down	p. 51
5.8	Checking Refrigerant Charge	p. 52
6	How To Use	p. 53
6.1	How To Use	p. 54
7	Error Diagnostics	p. 56
7.1	Error Diagnostics	p. 57
7.2	Notes	p. 60

1 Introduction

Introducing Cool Sleeping

Evening Breeze is a cool sleeping sensation which stands out in perfect temperature and humidity levels, clean air, no noise or draft and ease of use. Above all, the environmental impact is only marginal compared to conventional air conditioning. A real green dream... isn't that cool!

Fresh and Clean Air Silently Spread Across your Bed

The Evening Breeze is a patented bed climate system, which provides the sleeper with a sensational cool sleeping experience. A special ventilation system evenly spreads the conditioned air over your bed, resulting in direct local refreshment. Because the cooling is limited to the space where it is most needed - around your bed - you do not have to cool your whole room, resulting in less energy use and therefore a smaller energy bill.

Installation

In case you have not installed an Evening Breeze system before, this handbook will guide you through the steps needed to install, use and service this system. Please read this handbook carefully before proceeding with the installation of the system.

For more information about Evening Breeze and its products please visit our website: www.evening-breeze.com.

2 General Information

2.1 Your Package Should Contain	p. 8
2.2 Product Specifications	p. 9
2.3 Dimensions	p. 10

2.1 Your Package Should Contain

- a** Handbook
- b** Indoor Unit
- c** Outdoor Unit
- d** Remote Controller
- e** Packaged Aluminium Frame
- f** Ventilation System
- g** Filter

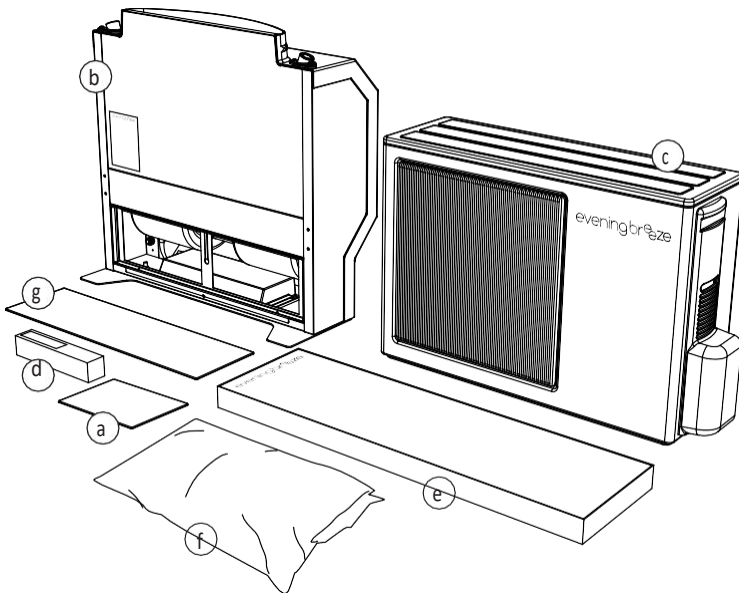

2.2 Product Specifications

Evening Breeze gen4 Cooling System

Refrigerant	R-410A (810g)
Power	200-240V at 50-60Hz
Cooling capacity (BTU)	6.000 (Turbo: 8.000)
Cooling capacity (W)	1.750 (Turbo: 2.350)
Cooling input power (W)	200 ~ 800
Cooling current (A)	0.9 ~ 3.5
Circuit breaker (A)	8
Air volume (m ³ /h)	250 ~ 450
Compressor brand	Sanyo
Compressor type	DC Twin Rotary
Weight indoor unit (kg)	30 (net) 33 (gross)
Weight outdoor unit (kg)	29 (net) 32 (gross)
Liquid side - gas side	1/4" - 3/8"
Max. pipe length (m)	25
Maximum fall (m)	10
Control unit	Wired remote

Ventilation System

Canopy	93% polyester/ 7% spandex
Air tube	60% polyester/ 40% cotton
Suspension system	Aluminium frame

2.3 Dimensions

Indoor Unit including Ventilation System

A = 86,6" / 2200 mm

B = 10,0" / 255 mm

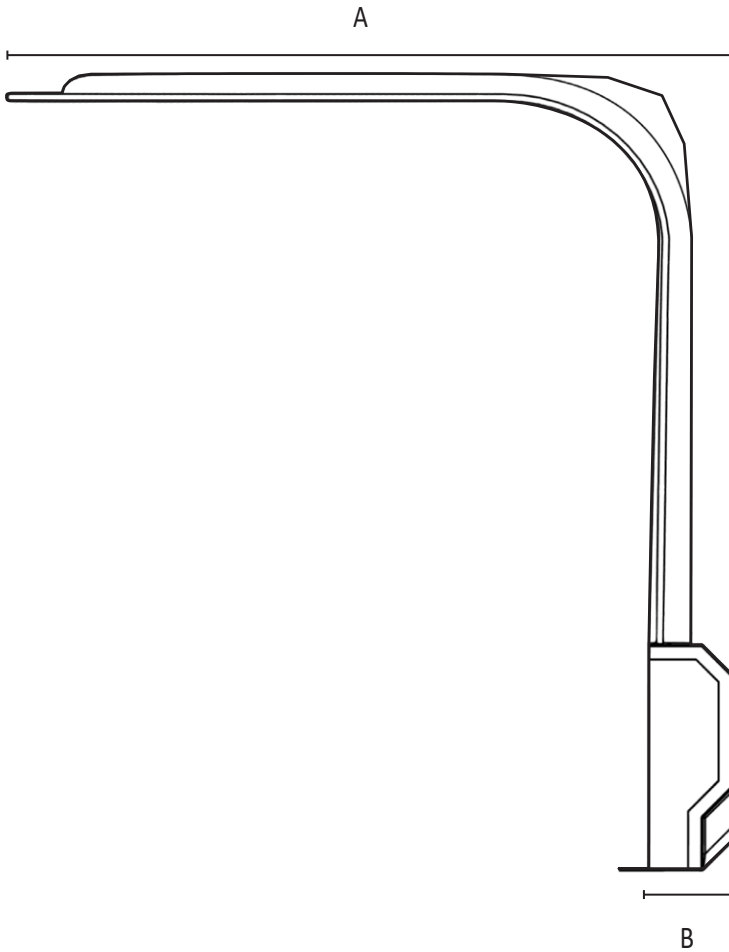

C = 73,2" / 1860 mm

D = 26,8" / 680 mm

E = 30,3" / 770 mm

F = 84,6" / 2150 mm

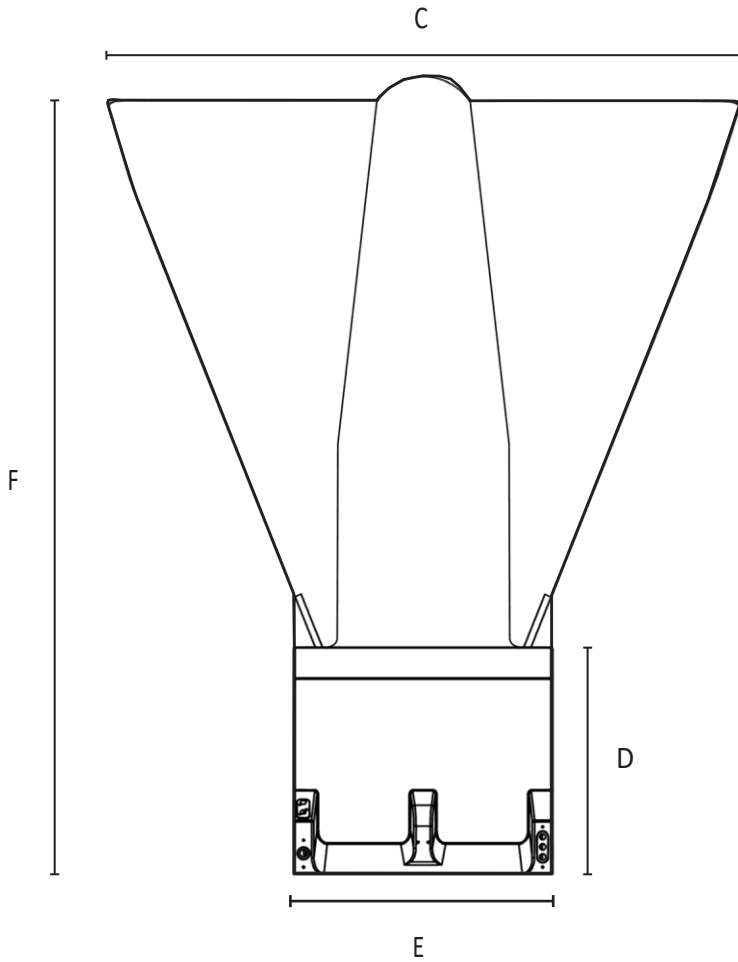

Outdoor Unit

A = 30,7" / 780 mm

B = 10,2" / 260 mm

C = 33,8" / 860 mm

D = 21,6" / 550 mm

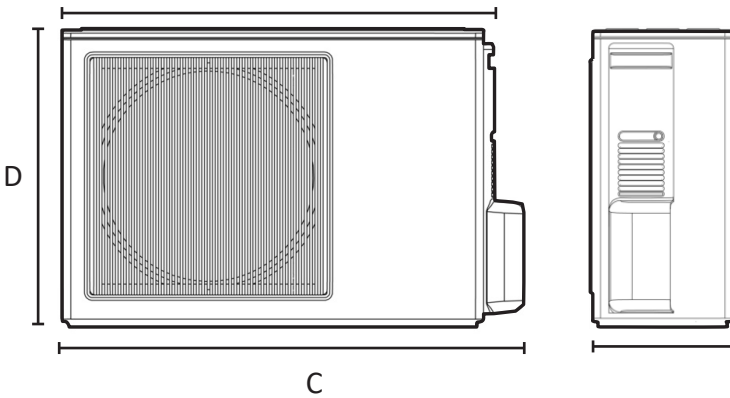

3 Installation - Cooling System

3.1	Refrigerant R-410A Information	p. 14
3.2	Precautions & General Information	p. 15
3.3	Needed Tools	p. 18
3.4	Unpacking	p. 18
3.5	Location	p. 20
3.6	Hole Placement	p. 24
3.7	Piping Connections	p. 26
3.8	System Pressurization	p. 30
3.9	Wrapping Valves & Pipes	p. 33
3.10	Ductwork	p. 34
3.11	Drainage	p. 35
3.12	Electronics	p. 36
3.13	Wiring Diagrams	p. 39

3.1 Refrigerant R-410A Information

- R-410A refrigerant operates at pressures above 100 Psi (7 bar). Ensure that the servicing equipment and replacement components used are designed to operate with R-410A.
- R-410A refrigerant cylinders have a dip tube which allows liquid to flow out of the cylinder in an upright position.
- R-410A systems should be charged with liquid refrigerant. Use a commercial type metering device in the manifold hose in order to vaporize the liquid refrigerant before it enters in the unit.
- R-410A refrigerant is only compatible with oils chosen by the compressor manufacturer. For this reason, for the type of oil to be used, always refer to the plate on the compressor and the unit.
- Carefully recover refrigerant within this unit before final disposal or when servicing. The recovered refrigerant must then be delivered to an appropriate disposal center or to the original equipment dealer.
- Never vent refrigerant into the atmosphere!

3.2 Precautions & General Information

- This installation manual describes the installation procedures of the Evening Breeze system.
- Installation and maintenance of this air conditioning system should only be carried out by trained and qualified personnel.
- Read this instruction manual thoroughly before starting the installation.
- Before doing any work on the unit, make sure that the power supply has been disconnected. Perform electrical work according to the installation handbook and be sure to use an exclusive circuit. Do not connect other electrical appliances to the circuit.
- Make sure the interior power supply cord and the main breaker capacity are sufficient and the installation area is sufficient and complies with the requirements.
- The indoor and outdoor unit comply with low-voltage (EEC/73/23) and electro-magnetic compatibility (EEC/89/336) directives.
- Follow all current national safety code requirements. In particular ensure that a properly sized and connected ground wire is in place.
- Check that voltage and frequency of the mains power supply are those required; the available power must be adequate to operate any other possible appliances connected to the same line. Also ensure that national safety code requirements have been followed for the mains supply circuit.

- Connect indoor and outdoor units with copper pipes by means of pre fabricated flare connections. Use insulated seamless refrigeration grade pipe only. Under no circumstances must sanitary type copper pipe be used.
- After installation thoroughly test the system operation and explain all system functions to the owner.
- Leave this manual with the owner for consultation during future periodic maintenance or error diagnostics.
- Use this unit only for factory approved applications: The outdoor unit is suitable for outdoor installation; the indoor unit is suitable for indoor installation.
- The in- and outdoor unit and its components must be periodically inspected to check for loose, damaged or broken parts. If these faults are found and not eliminated, the unit could cause physical injury to persons and damage to goods and property.
- Do not place water containers (for example vases) on the indoor or outdoor unit.
- Before cleaning it is necessary to disconnect the power supply of the indoor unit.
- Coupling units which have different control systems, may cause irreversible damage and void the warranty protection.
- The manufacturer declines any liability for system malfunction resulting from unapproved coupling.
- The manufacturer declines any liability for damage resulting from modifications or errors in the electrical or refrigerant connections.
- Failure to observe electric safety codes may cause a fire hazard in case of short circuits.
- Inspect equipment for damage due to improper transportation or handling.
- Do not install or use damaged units.

- Never open system to atmosphere while it is under vacuum.
- Dispose of the packaging material in accordance with local requirements.



During installation first make refrigerant connections before the electrical connections. When disassembling the unit, first disconnect electrical cables and then refrigerant connections.



Disconnect the mains power supply switch before servicing the system or handling any internal parts of the unit.

3.3 Needed Tools

- Copper piping (1/4" and 3/8")
- Pipe insulation (minimum thickness of 1/4" (6mm))
- Wiring (4 x 1,5mm²)
- Drainage pipe (16mm)
- Screwdriver
- Torque wrench
- Hole drill (60mm)
- Tape measure
- Pipe cutter
- M6 Allen key
- Manifold gauge
- Flare tool set
- Brazing equipment
- Vacuum pump (2-stage)
- Dry nitrogen cylinder (reducible)
- Bending pliers (1/4" and 3/8")
- Vinyl tape

3.4 Unpacking

Unpacking the indoor unit should be done following the instructions on the next page. First the packaging should be removed. Then the foot of the base should be rotated. Unscrew the two nuts inside the indoor unit, rotate the foot of the indoor unit 180 degrees, then tighten the nuts again on the foot.

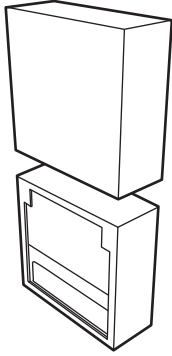

1

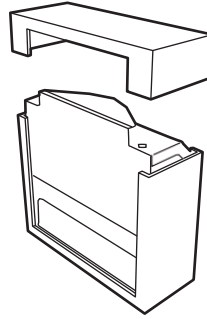

2

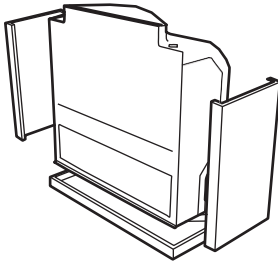

3

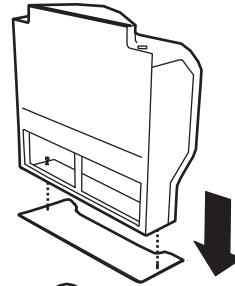

4

2x

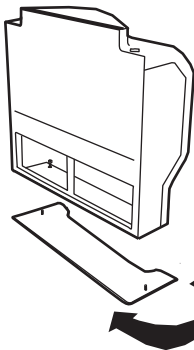

5

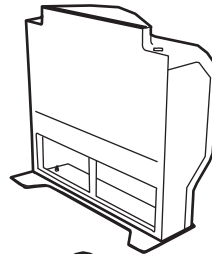

6

2x



3.5 Location

Take care in choosing the right position for both the indoor and the outdoor unit. Here are some tips to help you choose the ideal location.

Indoor Unit

- Place the indoor unit at the exact center of where the headend of the bed will be.
- Ideally the indoor unit should be placed against an outer wall so the piping, drainage and wiring can easily be lead outwards to the outdoor unit.

Outdoor Unit

- Choose a position that allows for the clearances required, see page 18.
- Choose a position protected from opposing winds, see Figure 1 on page 17.
- Floor structure should be adequately strong to support unit weight and minimize vibration transmission.
- The supporting frame should be strong and secure. The unit should be on a horizontally level surface.
- The outdoor unit can be installed on the floor and on the wall using appropriate brackets.
- Consider a position which will not obstruct passageways or doors.
- If the unit is installed in areas where heavy snowfalls may occur, it is necessary to raise its level at least 7,9"/ 200mm above the usual snow level or alternatively to use outdoor unit appropriate brackets.

- Choose an area close to the indoor system to limit the length of copper tubing and drainage needed. Minimum length is 6ft / 2m. Max length is 80 ft/ 25m. Max fall is 30ft / 10m.
- The outdoor unit can be noisy so consider neighbors or animal housing when placing the unit.
- Ideally the unit should be sited in the shade to avoid the heat of the sun as this can affect cooling performance.
- Do not keep animals or plants near the installation location as the hot air from the outdoor unit will affect them.
- Do not allow any overgrowth to grow into the unit, check it twice a year to ensure it is free from all obstructions.

Avoid:

- Exposing the unit to direct sunlight and sea winds.
- Placing the unit too close to sources of heat radiation, vapor or flammable gas.
- Placing the unit in particularly dusty areas.
- Multiple unit installation with units facing each other, see Figure 2 on page 17.

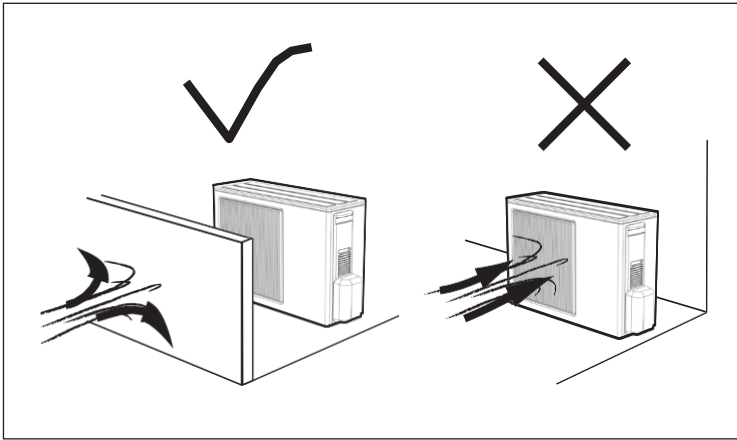

Figure 1. Choose a position protected from opposing winds

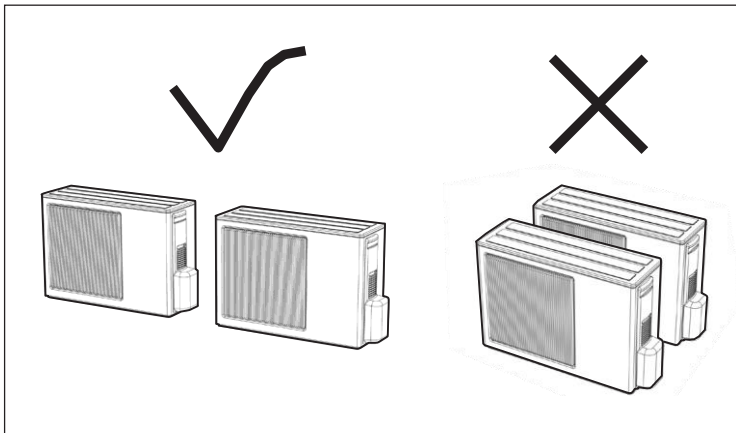

Figure 2. Avoid multiple unit installation with units facing each other

Minimum clearance

A = 4" / 100 mm

B = 20" / 500 mm

C = 10" / 250 mm

D = 4" / 100 mm

E = 24" / 600 mm

F = 16" / 400 mm

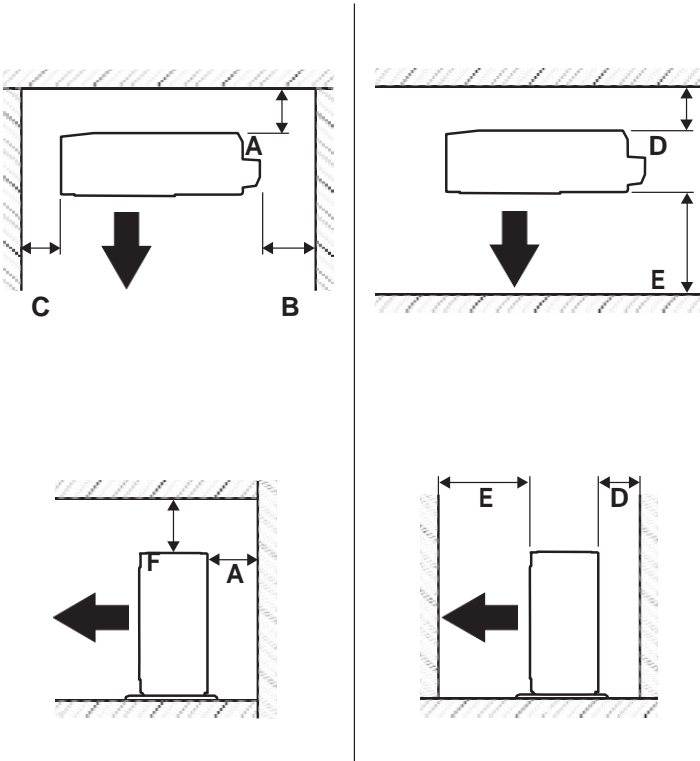

3.6 Hole Placement

The piping, drainage and wiring need a hole outward with a diameter of at least 2 1/2" (60mm). Carefully consider the area where you want the hole to be placed.

- Ideally the piping and drainage should exit the indoor unit at the lower right corner and be guided outside through the floor or wall (see Figure 3).
- Consider the area where you want to have the outdoor unit installed when choosing the placement of the hole.
- When placed in the wall, the location of the hole should not be higher than 4" (100mm) from the floor, this is because of the gravity forced drainage. In case gravity forced drainage is not possible, make use of a pump.

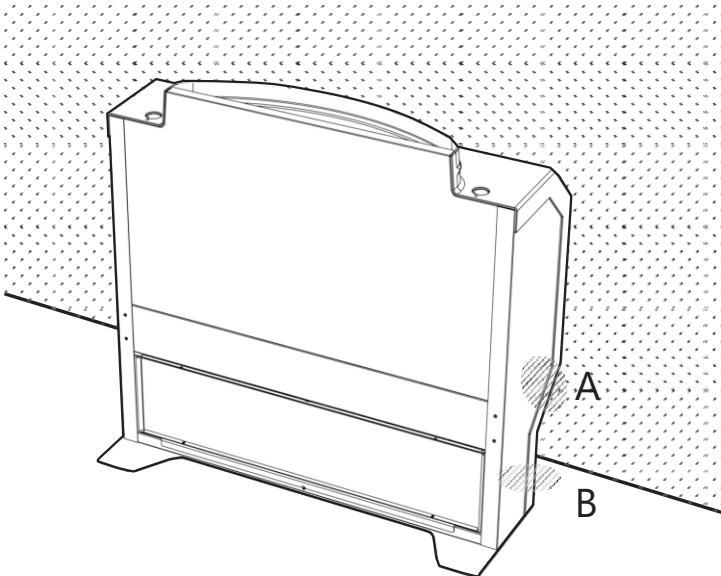

Figure 3. The ideal hole locations at the lower right corner of the system
A. in the wall / B. in the floor

COPPER PIPING

The copper pipes used with this system should have the following inner diameter:

Liquid pipe: 1/4" (6,35mm)

Gas pipe: 3/8" (9,52mm)

To prevent energy loss and forming of condensate, the two pipes must be insulated separately with an insulation thickness of at least 1/4" (6mm).

3.7 Piping Connections

The installation of the piping and the pressurization of the system should be done by qualified service personnel only!

- Connect indoor and outdoor units with field supplied copper pipes by means of pre-fabricated flare connections. Use insulated seamless refrigeration grade pipe only. Under no circumstances must sanitary type copper pipe be used.
- When laying the piping, protect the open end of the pipe against dust and moisture (see Figure 4) by carefully shielding them with tape or a protection cap (see Figure 5).
- In case brazing is necessary, braze with dry nitrogen (N₂).
- All pipe bends should be as gentle as possible. Use a pipe bender for bending (see Figure 6). The bending radius should be 1 1/4" (30mm) or larger.
- Where required, the unit must be charged with (additional) refrigerant, charge refrigerant only in liquid phase.
- Insufficient tightening torque will cause gas leaks. Overtightening the fittings will damage the tube flaring and cause gas leaks.
- Finger-tighten the fitting (flare) several turns, then tighten it with a (torque) wrench (see Figure 7) by applying the tightening torque indicated in table 1.

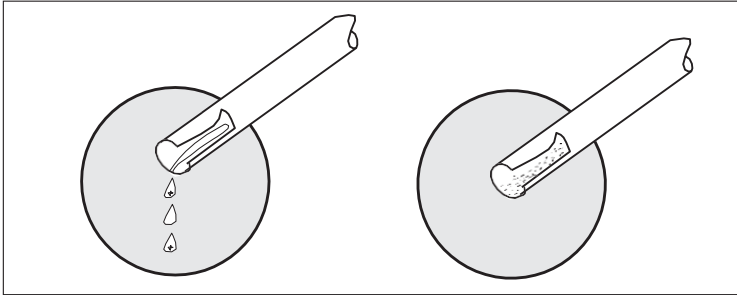

Figure 4. Dirty pipe-ends.

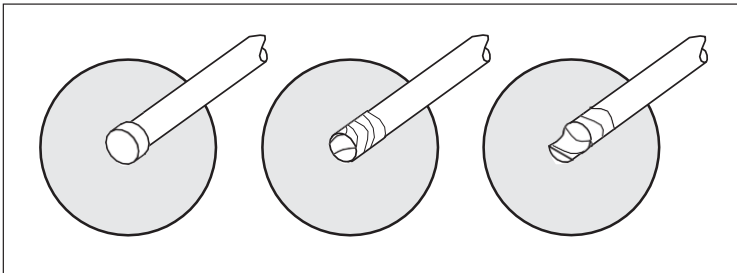

Figure 5. Pipe caps.

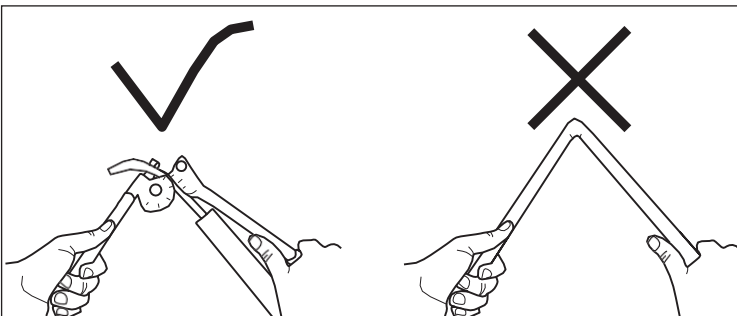

Figure 6. Gently bend the pipes with a pipe bender.

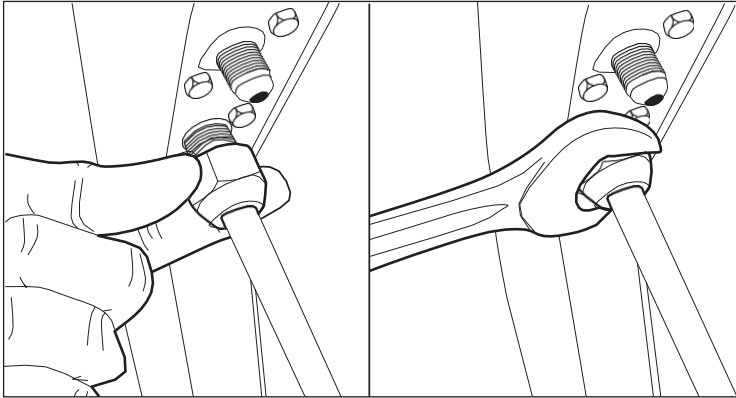

Figure 7. First finger tighten the nut, then tighten it with a wrench.

Table 1. Flare nut tightening torque

Gas side (3/8" or 9,52mm)	Liquid side (1/4" or 6,35mm)
42 N·m (425 kgf·cm)	18 N·m (180 kgf·cm)

Flaring the Pipes

If additional flaring is needed, please follow these steps:

1. Remove protective caps from copper tube ends.
2. Cut the pipe to length with a pipe cutter.
3. Remove burrs with the cut surface facing downward so that the chips do not fall into the pipe.
4. Put the flare nut on the pipe.
5. Flare the pipe end.
6. Check that the flaring is properly done (see Figure 8, Figure 9 and Figure 10).
7. Coat the flare with special R-410A refrigeration oil to prevent leaks in the future. The maximum residual quantity of oil used for tubing is 40 mg/10m.

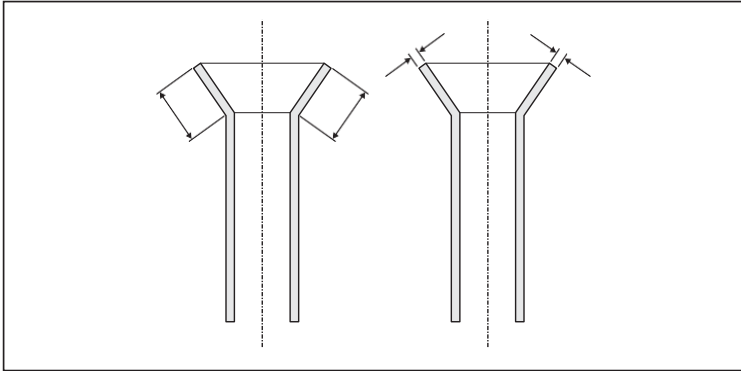

Figure 8. A proper flare has the same length and wall thickness all around.

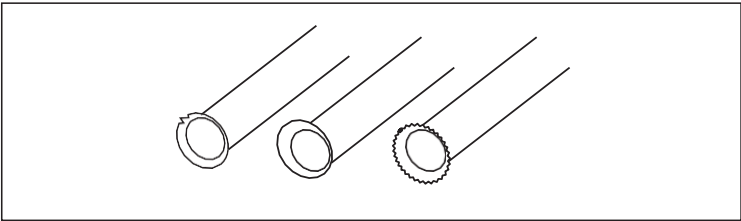

Figure 9. Examples of unusable flares.

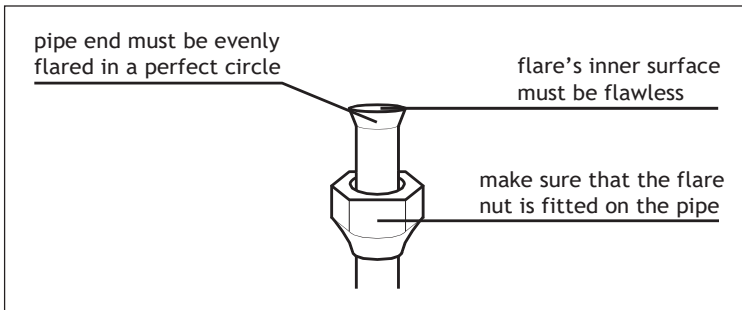

Figure 10. Check to see that the flaring on the pipes is done correctly.

3.8 System Pressurization

After connecting all the pipes, perform the following operations on the piping connections of the outdoor unit (see Figure 11):

Check for Leaks

1. Remove screw cap E.
2. Make sure both the gas and liquid valve are closed.
3. Connect the manifold gauge to the service valve.
4. Connect the dry nitrogen to the manifold gauge.
5. Put the system up to a pressure of maximum 25 bar with dry nitrogen.
6. After 30 minutes check if the pressure is still 25 bar, if not, there's a leakage. Check the connections and if necessary, improve them. Then do the test again.

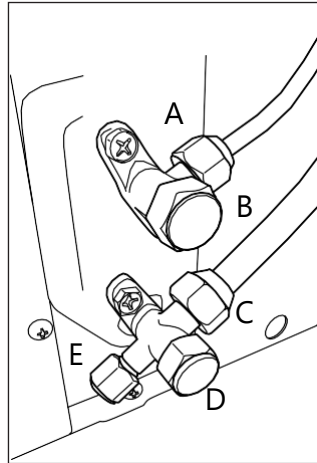

Figure 11. The connections on the outdoor unit

Evacuate Piping

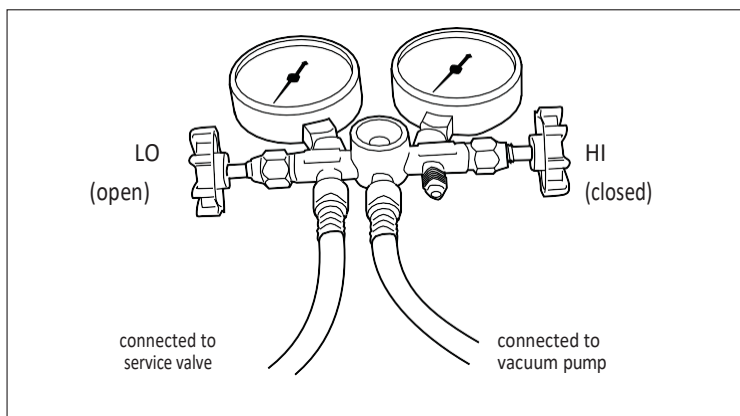

Figure 12. The manifold gauge

1. Remove the service valve caps from B, D and E (see Figure 11). Note that all the valves on the outdoor unit are kept closed at this stage.
2. Connect the left connector on the manifold to the service valve on the outdoor unit (see Figure 12).
3. Connect the vacuum pump to the middle connector of the manifold (see Figure 12).
4. Confirm the “LO” knob of the manifold valve is open
5. Run the vacuum pump
6. The operation time for evacuation varies with tube length and capacity of the pump, but is generally around 15 min
7. When the desired vacuum is reached, close the “LO” knob of the manifold valve and stop the vacuum pump



Never use the system compressor as a vacuum pump and never use the unit refrigerant gas to purge the connecting pipes.

Filling the Pipes

After evacuating the pipes, the system should be filled with refrigerant.

1. Fully open the liquid valve by using an Allen key and turning counter-clockwise (see Figure 11 on page 25).
2. Now open the gas valve by using an Allen key and turning counter-clockwise (see Figure 12 on page 26).
3. Remove the manifold gauge connected to the service valve.
4. Replace the screw caps B, D and E.

3.9 Wrapping Valves & Pipes

Finally wrap the valves and pipes with anti-condensate insulation and if necessary, tighten this with tape, without exerting too much pressure on the insulation.

Repair and cover any possible cracks in the insulation.

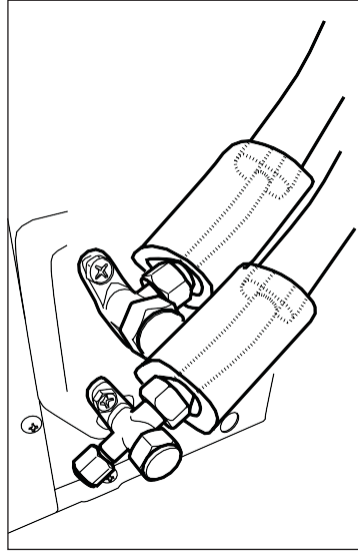
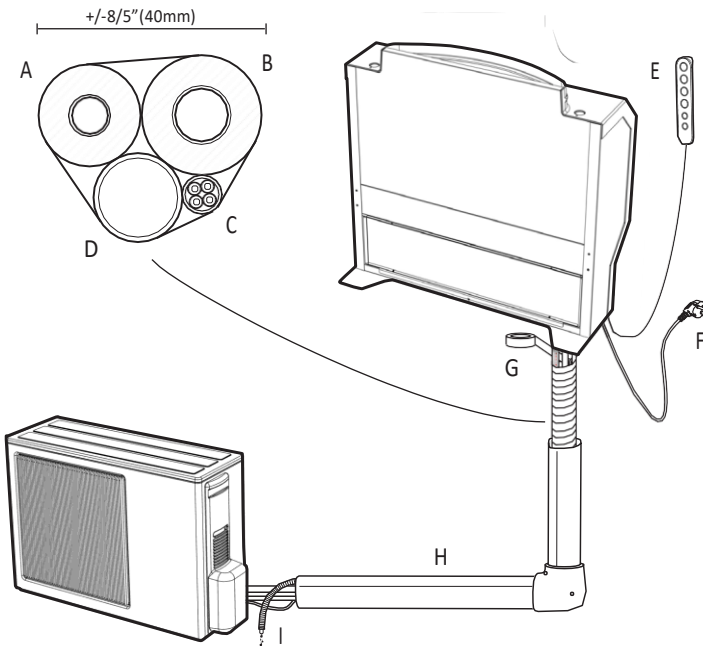

Figure 13. Wrapping the valves and pipes.

3.10 Ductwork

Combining the piping, drainage and wiring will provide a clean look. Evening Breeze recommends using special cable ducts. Please take the following steps:

1. Cut the drainage pipe and the wiring to size.
2. Bundle them with the insulated copper piping.
3. Use vinyl tape to keep the bundle together and shield the wiring and piping.
4. Apply the special cable ducts.



- | | | | |
|---|-----------------------------------|---|------------|
| A | Insulated liquid pipe (1/4") | F | Power cord |
| B | Insulated gas pipe (3/8") | G | Vinyl Tape |
| C | Wiring (4 x 1,5 mm ²) | H | Cable duct |
| D | Drainage pipe (16mm) | I | Drainage |
| E | Remote Control | | |

3.11 Drainage

When used in humid areas/times the cooling system produces a large amount of condensate, up to 20 liters per night.

It is important that all the condensate is drained from the system, for this purpose a drainage pipe must be connected at the back of the indoor unit.

The drainage pipe should be guided outward in a sloping manner. In this way the condensate can be transported outdoors by the use of gravity.

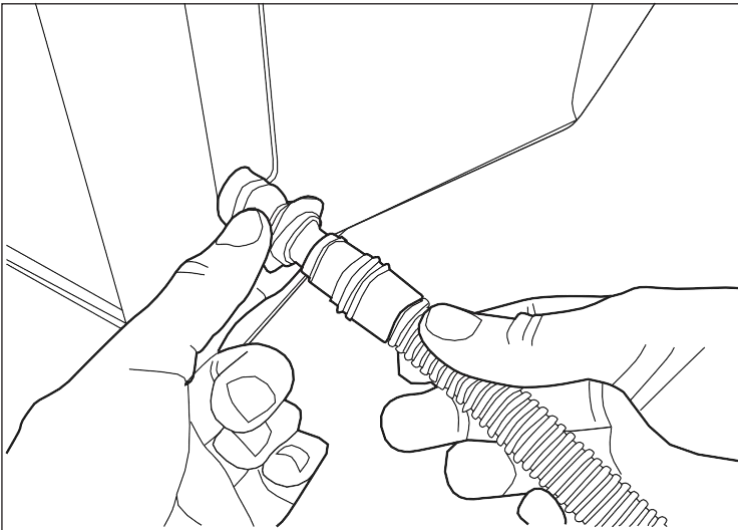

Figure 14. Connect the drainage pipe to the drain tube at the back of the indoor unit.

3.12 Electronics

- When installing the electronics be sure to use exclusive circuits. Wiring work should be based on applicable technical standards and executed by a qualified installer.
- Make refrigerant connections before electrical connections. When disconnecting, disconnect electrical connections before refrigerant connections.
- Make ground connection prior to any electrical connections.
- All field electrical connections are the responsibility of the installer.

Connect Wiring to the Outdoor Unit

1. Remove the side cover (see Figure 15).
2. Connect the wiring according to the “outdoor wiring diagram” on page 34.
3. Make sure you fasten the cable pull relief (see Figure 17).
4. Place back the side cover and fasten the screw.

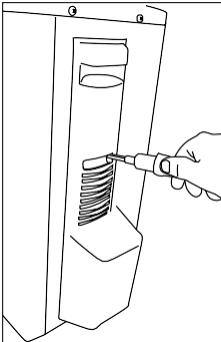

Figure 15. Remove the side cover.

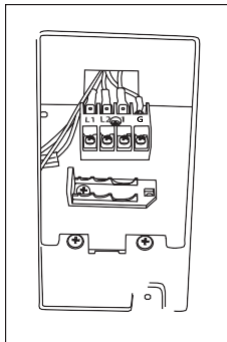

Figure 16. Connect the wiring.

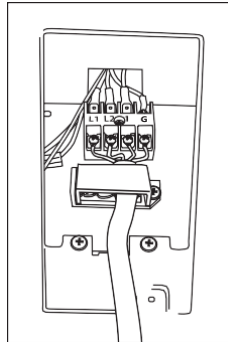

Figure 17. Fasten the cable pull relief.

Connect Wiring to the Indoor Unit

1. Gently pull away the filter (see Figure 18).
2. Unscrew the five screws from the filter housing (see Figure 19).
3. Unscrew the single screw of the electronic box connecting it to the indoor unit (see Figure 20).
4. Unscrew all 4 screws of the electronic box (see Figure 21)

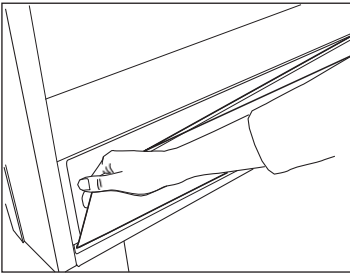

Figure 18. Pull away the filter.

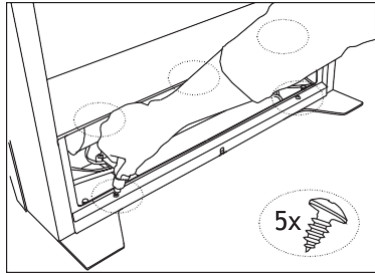

Figure 19. Unscrew 4 screws from filter housing.

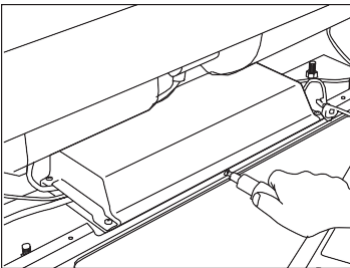

Figure 20. Unscrew single screw of electronic box.

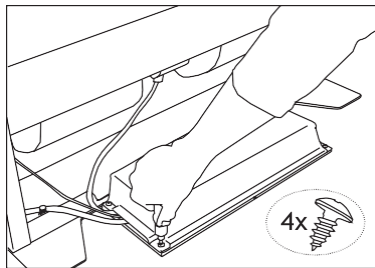
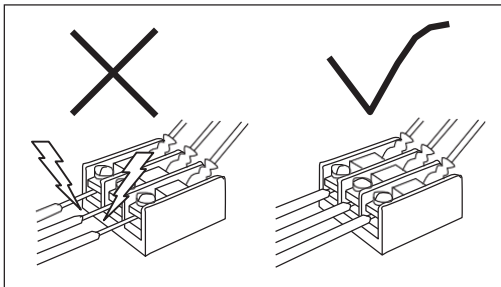

Figure 21. Unscrew all 4 screws of electronic box.

5. Connect the wiring according to the “indoor wiring diagram” on page 34).



Make sure there is no slack in the electrical connections and the insulation of the conductors is properly stripped.



6. Make sure you fasten the cable pull relief.
7. Check Turbo switch (see figure 22) on INDOOR PCB unit. Engaging the Turbo mode allows for more cooling power (7.000 BTU) and has a different thermostat control logic, only for extreme high temperature regions.
8. Put all the components back in place by repeating step 4 to 1.

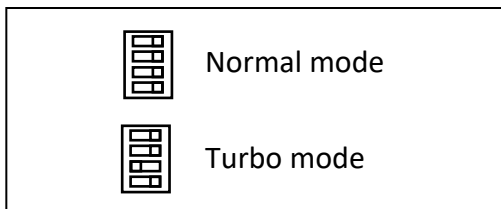
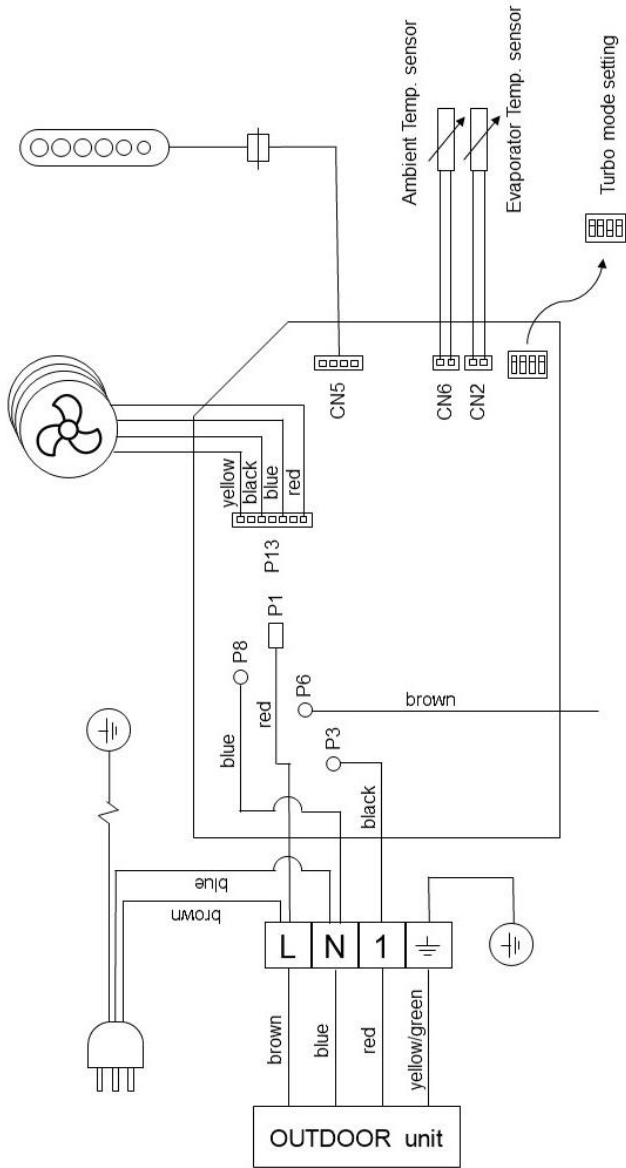

Figure 22. Turbo switch

3.13 Wiring Diagrams

INDOOR Wiring diagram (gen3-4)



OUTDOOR Wiring diagram (gen4)

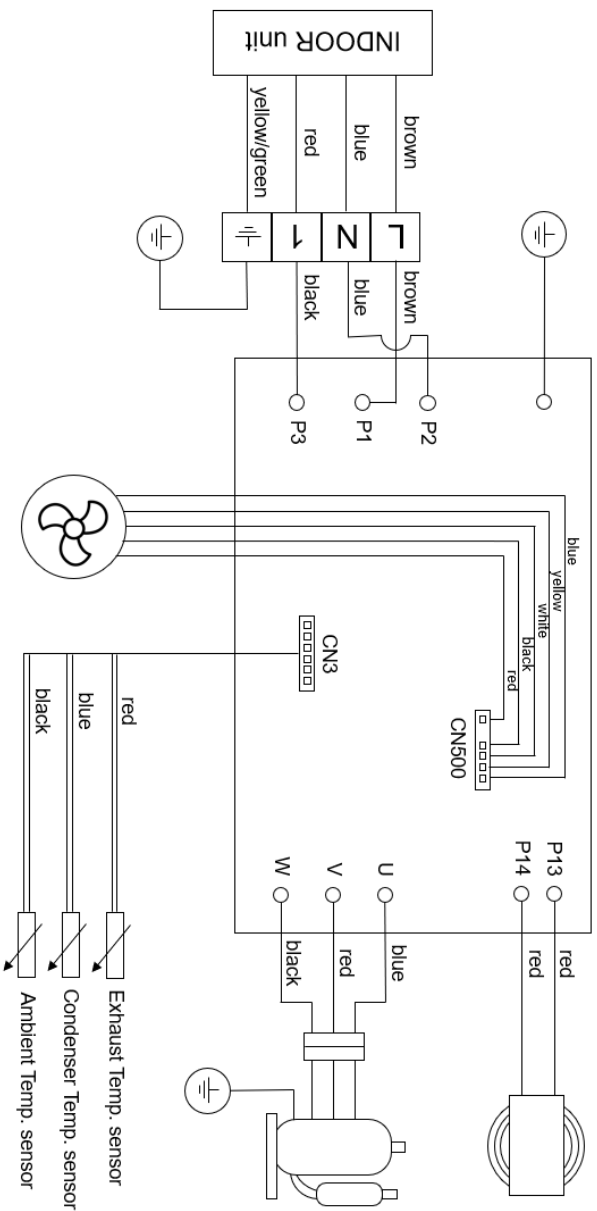

4.1 Bed Requirements & Placement

- The bed head-end should have an open space at the bottom of at least 6" (150 mm) high and 30" (770 mm) wide.
- The height of the head-end should at least be 28" (700 mm) and at most 50" (1250 mm).
- The bed/head-end should be placed in the middle of the system, like in the figure below.

A Min.	=	28"	/	700mm
A Max.	=	50"	/	1250 mm
B Min.	=	30"	/	770 mm
C Min.	=	6"	/	150 mm

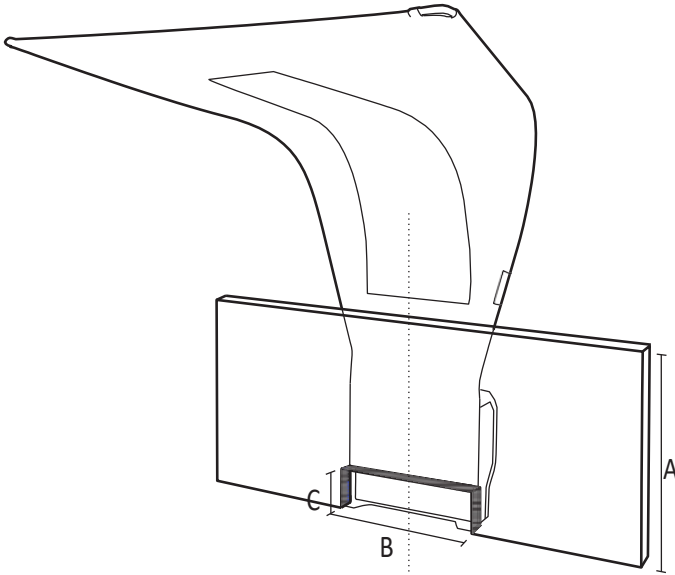

4.2 Ventilation System

The ventilation system dissipates the cooled air evenly across the sleepers. It's placed on top of the indoor unit. It exists of a framework of 12 poles and a textile sock. For the steps where it's necessary to add a pole the appropriate pole character is shown in the pictures on the next page.

This letter refers to the pole in Figure 23. Before installing the ventilation system, please check the if the frame is complete.

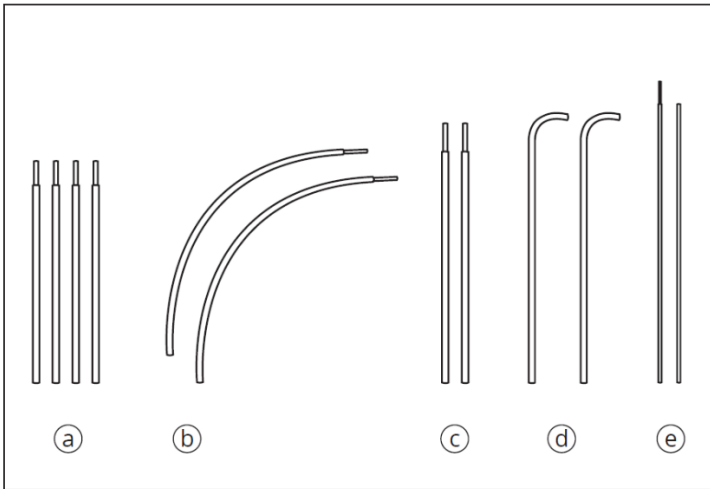
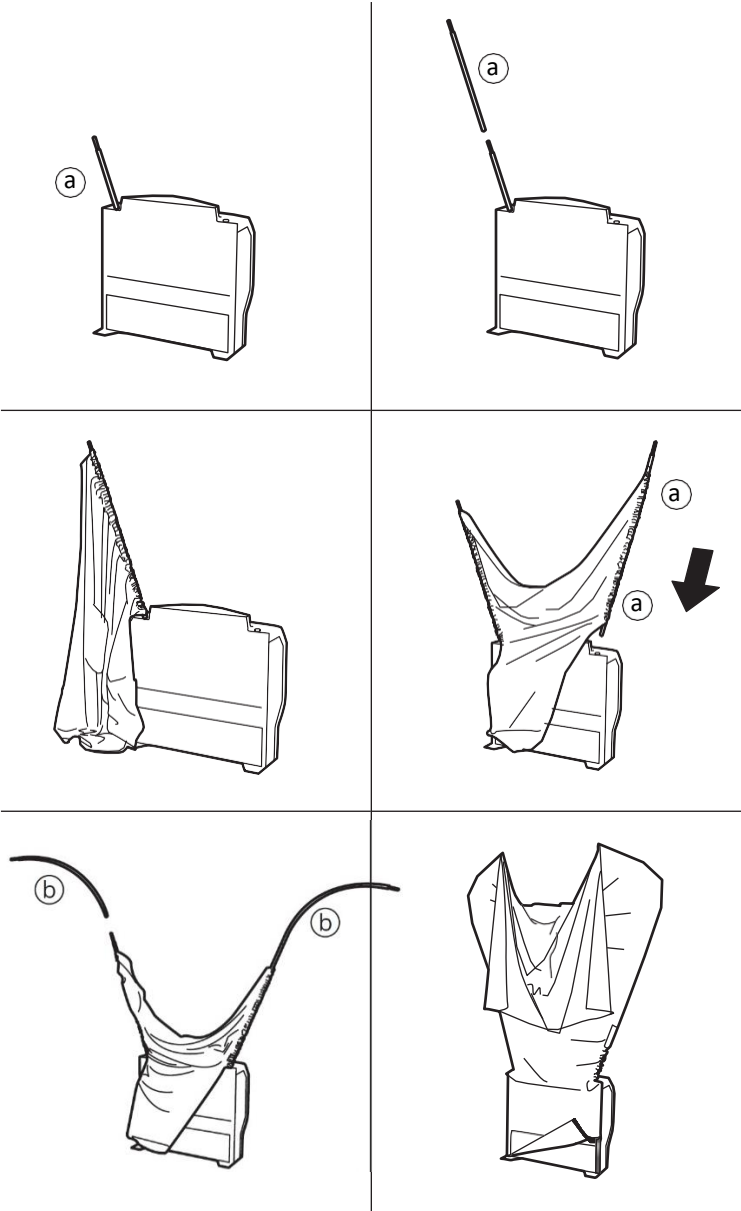
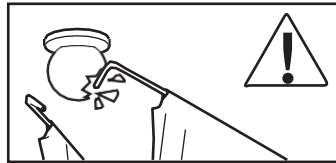
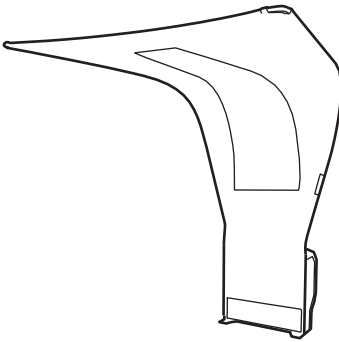
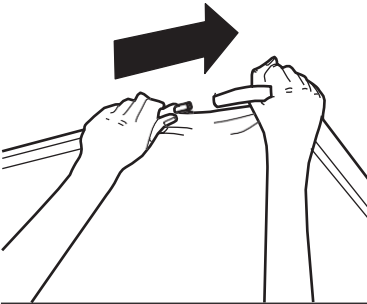
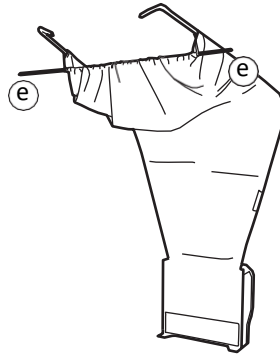
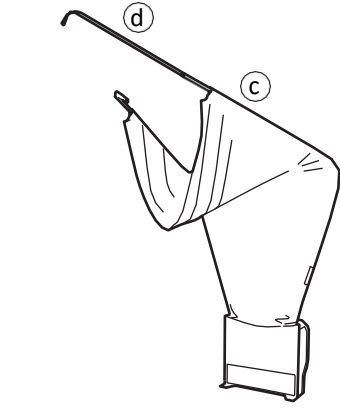

Figure 23. Overview of the different poles in the ventilation system.





5 Maintenance

5.1 Regular Tasks	p. 46
5.2 Cleaning the Air Filter	p. 46
5.3 Cleaning the Indoor Unit Evaporator Coil	p. 47
5.4 Cleaning the Ventilation Sock	p. 48
5.5 Vacuum Cleaning the Outdoor Unit Coil	p. 49
5.6 Disinfecting the Outdoor Unit Coil	p. 50
5.7 Pump Down	p. 51
5.8 Checking Refrigerant Charge	p. 52

5.1 Regular Tasks

The lifetime of the system largely depends on the quality of service and maintenance. Some parts of the Evening Breeze system require regular cleaning. Evening Breeze strongly advises to clean the following parts regularly:

Indoor unit:

- The air filter at least twice a year
- Evaporator coil at least once a year
- Ventilation sock at least once a year

Outdoor unit:

- Condenser coil at least once a year

On the following pages these maintenance tasks will be explained briefly.

5.2 cleaning the Air Filter

To ensure proper and efficient functioning of the system as well as dirt and pollutant free air, the filter should be cleaned regularly. Depending on the location and frequency of use this can differ from 2 to 6 times a year. Please follow the steps below on how to clean the filter.

1. Switch the mains supply OFF.
2. Take out the filter screen (see Figure 24).
3. Rinse it with cool water.
4. If necessary replace the dirty filter screen with a new one.

5.3 cleaning the Evaporator Coil

The following maintenance operations must be carried out by qualified personnel. The evaporator coil should be cleaned with a special coil cleaner (Evening Breeze recommends EasyCare® evaporator cleaner). This is done to kill bacteria, mold, slime and algae that builds up on evaporator coils.

1. Switch the mains supply OFF.
2. Take the air tube from the top of the indoor unit.
3. Spray the evaporator coil with evaporator cleaner/ disinfectant spray.



Do not spray on to the fabric of the CANOPI, this will cause stains.

4. Wait for 10 minutes.
5. Carefully rinse the coil with a water spray.

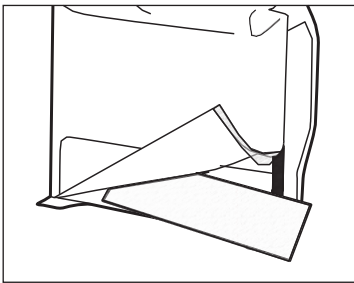

Figure 24. Taking out the filter.

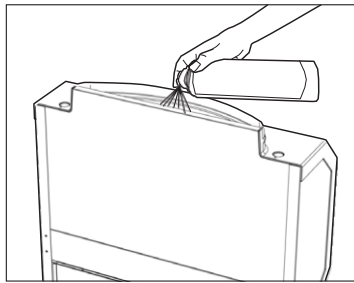

Figure 25. Spraying the evaporator coil.



Do not use too much water, this will cause leakage into the fans and can eventually lead to short circuiting. When not sure if too much water is used check the fan compartment for water by removing the air filter (see 'Cleaning the air filter').

6. Run the system on FAN for 10 minutes.
7. Put the air tube back on the indoor unit.

5.4 Cleaning the Ventilation System

The ventilation system is a crucial part of the Evening Breeze system. In dusty areas the ventilation system can get clogged after longer periods of use. The fabric can also get stained or smudged by other external influences. To guarantee proper functioning of the ventilation system, Evening Breeze strongly advises to clean the fabric at least once a year. Please follow the steps below on how to clean the sock.

1. Take off the ventilation system by repeating all steps in chapter "4 Installation - Ventilation System" on page 35 backwards.
2. Wash according to the washing label (max 30 °C, no bleach, no dry clean, no tumble dry, no iron).
3. Place back the ventilation system by following the steps in chapter "4 Installation – Ventilation System" on page 35.

5.5 Vacuum Cleaning the Outdoor Unit Coil

The following maintenance operations must be carried out by qualified personnel.

When necessary, proceed as follows for careful cleaning of the coil:

1. Switch the mains supply OFF.
2. Remove unit top cover by loosening holding screws and lifting the cover.
3. Carefully clean the coil with a vacuum cleaner (see Figure 28 on page 45).
4. Dust the inside of the fan compartment and the fan blades. Avoid any damage to the blades that may cause future vibrations and noise.
5. Put back the unit cover and tighten the screws.

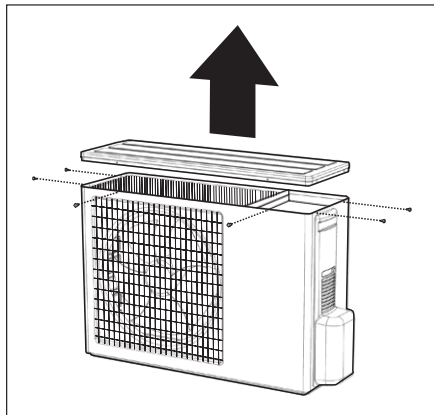

Figure 26. Remove unit top with 6 screws.

5.6 Disinfecting the Outdoor Unit Coil

The following maintenance operations must be carried out by qualified personnel. The evaporator coil should be cleaned with a special coil cleaner. This is done to kill bacteria, mold, slime and algae that builds up on evaporator coils.

1. Switch the mains supply OFF.
2. Remove unit top cover by loosening holding screws and lifting the cover.
3. Spray the evaporator coil with evaporator cleaner/ disinfectant spray.
4. Wait for 10 minutes.
5. Carefully rinse the coil with a water spray.



Do not use too much water, this can cause damage and may lead to short circuiting.

6. Put back the unit cover and tighten the screws.
7. Run the system on COLD for 10 minutes.

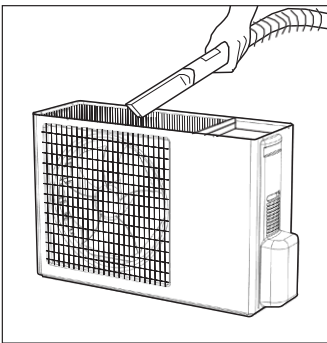

Figure 27. Vacuum cleaning the outdoor unit coil.

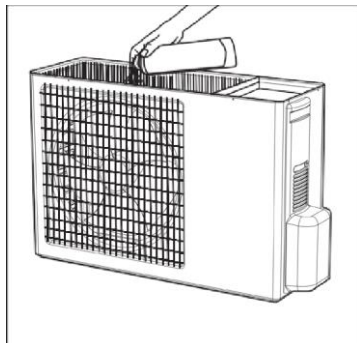

Figure 28. Spraying the coil.

5.7 Pump Down

The following maintenance operations must be carried out by qualified personnel. Pump-down is an operation intended to collect all the system refrigerant in the outdoor unit. This operation must be carried out before disconnecting the refrigerant piping in order to avoid refrigerant loss to the atmosphere. After removal, unit must be delivered to an appropriate disposal center or the original dealer.

1. Shut off the liquid valve with the Allen wrench.
2. Turn the system on in COLD mode (Compressor will immediately start, provided 3 minutes have elapsed since the last stop).
3. After maximum 20 seconds of operation, shut the suction valve with the same wrench.
4. Turn the system OFF and switch mains supply OFF.
5. Disconnect tubing.
6. After disconnection, protect valves and tubing ends from dust and dirt.



Compressor damage may occur if run at a negative Suction pressure.

5.8 Checking Refrigerant Charge

This check becomes necessary after any refrigerant leak due to incorrect connection, or after replacement of the compressor.

1. The best method to correctly charge refrigerant is to completely empty the refrigerant circuit using refrigerant recovery equipment.
2. Then charge the exact quantity of refrigerant according to the data shown on the unit nameplate (810 gr). This can be done with charging equipment of the “Dial a charge” type.
3. Charge R-410A units with cylinder in upright position and a commercial-type metering device in manifold hose in order to vaporize the liquid refrigerant before it enters in the unit.
4. Charge refrigerant into suction-line.

R-410A refrigerant cylinders contain a dip tube which allows liquid refrigerant to flow from the cylinder in an upright position. For more information about R-410A see chapter “3.1 Refrigerant R-410A Information” on page 9.

6 How To Use

6.1 How To Use

p. 54

6.1 How To Use

The Evening Breeze system is very easy to use. The remote control has only 6 buttons. When the user moves the remote control, the buttons automatically light up.

Turn on the System

To turn on the Evening Breeze system, the user can select one of the 4 cooling modes; FAN, FRESH, COOL or COLD. When the cooling mode is selected, the color of the corresponding button will turn blue. On the next page you can see the different cooling modes and their explanation.

Turn off the System

The Evening Breeze system can be turned off by simply pushing the OFF button. The button will light up red and the backlight of the remote control will slowly fade in approximately 5 seconds. Indoor unit fans will continue to run for another 30 seconds to dry the evaporator coil.

GENTLE Mode

When the system is in cooling mode, the user can choose to lower the fan speed by pushing the GENTLE button. The button will light up green, which indicates that the fans are running on low speed. This function reduces the sound level, the air refresh rate and total available capacity.

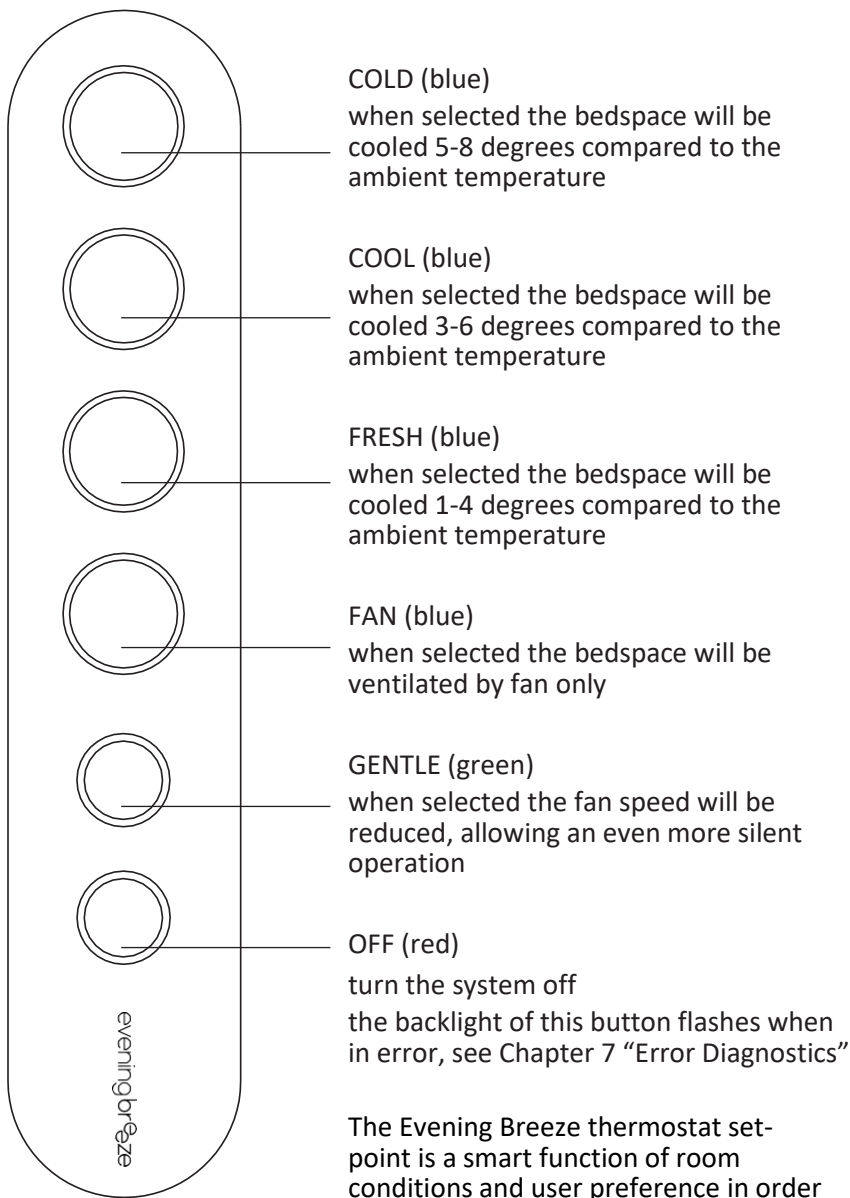

The Evening Breeze thermostat set-point is a smart function of room conditions and user preference in order to provide the best possible sleeping climate; the exact cooling varies, especially at higher and lower ambient temperatures.

7 Error Diagnostics

7.1 Error Diagnostics

p. 57

7.2 Notes

p. 60

7.1 Error diagnostics

In case of a failure in the system, the red light of the OFF button will flash a number of times. The error corresponding to the number of flashes is displayed below:

	status	probable cause	action
1x	Abnormal input power	The input power is too high or too low	Check your power supply and make sure it is stable
2x	Indoor coil sensor fault (1)	<ol style="list-style-type: none"> 1. Sensor plug is loose 2. Indoor unit sensor is open- circuit or short-circuit 3. Indoor PCB is defective 	<ol style="list-style-type: none"> 1. Connect the plug 2. Replace the sensor 3. Replace the indoor PCB
3x	Indoor ambient temperature sensor fault	<ol style="list-style-type: none"> 1. Sensor plug is loose 2. Indoor unit sensor is open- circuit or short-circuit 3. Indoor PCB is defective 	<ol style="list-style-type: none"> 1. Connect the plug 2. Replace the sensor 3. Replace the indoor PCB
4x	Indoor coil sensor fault (2)	<ol style="list-style-type: none"> 1. Sensor plug is loose 2. Indoor unit sensor is open- circuit or short-circuit 3. Indoor PCB is defective 	<ol style="list-style-type: none"> 1. Connect the plug 2. Replace the sensor 3. Replace the indoor PCB
5x	Outdoor coil sensor fault	<ol style="list-style-type: none"> 1. Sensor plug is loose 2. Outdoor unit sensor is open- circuit or short-circuit 3. Outdoor unit PCB is defective 	<ol style="list-style-type: none"> 1. Connect the plug 2. Replace the sensor 3. Replace the outdoor PCB
7x	Frost protection activated	<ol style="list-style-type: none"> 1. The filter of the indoor unit and/or the evaporator is too dirty 2. The indoor unit coil temperature is too low 3. The refrigerant pressure in the system is too low 4. Indoor unit coil sensor failure 5. Indoor unit PCB is defective 	<ol style="list-style-type: none"> 1. Clean the indoor unit filter and/or the evaporator 2. The system will return to its normal working order after temperature has risen 3. Check the system pressure. If pressure is too low, check the system for leakage. If there is no leakage, refill the system 4. See 'Indoor coil sensor fault' 5. Replace the indoor unit PCB
8x	Wired controller communication fault	<ol style="list-style-type: none"> 1. The connector is disconnected or does not make contact 2. The wiring between PCB and controller is defective 3. The indoor unit PCB is defective 	<ol style="list-style-type: none"> 1. Reconnect the connectors 2. Replace the PCB to controller cable 3. Replace the wired controller 4. Replace the indoor unit PCB

	status	probable cause	action
9x	Wiring fault	<ol style="list-style-type: none"> 1. The wiring between the in- and outdoor unit is faulty 2. The indoor unit PCB is defective 3. The outdoor unit PCB is defective 	<ol style="list-style-type: none"> 1. Check the wiring according to the wiring diagram and reconnect the wires 2. Replace the indoor unit PCB 3. Replace the outdoor unit PCB
10x	Compressor start fault	<ol style="list-style-type: none"> 1. The connector is disconnected or does not make contact 2. Outdoor unit PCB failure 3. Compressor failure 	<ol style="list-style-type: none"> 1. Reconnect the connector according to the wiring diagram 2. Replace the outdoor unit PCB 3. Replace the compressor
11x	Outdoor unit over-current	<ol style="list-style-type: none"> 1. Voltage fluctuations causes by instantaneous over-current 2. Outdoor unit is poorly ventilated 3. Condenser is too dirty 4. Outdoor fan or blower capacitor failure 5. Outdoor temperature is too high 6. Outdoor unit PCB is defective 	<ol style="list-style-type: none"> 1. Check the current 2. Improve the ventilation of the outdoor unit 3. Clean the condenser 4. Replace the outdoor fan or blower capacitor 5. Improve the ventilation of the outdoor unit 6. Replace the outdoor unit PCB
12x	Compressor exhaust temperature sensor failure	<ol style="list-style-type: none"> 1. The connector is disconnected or does not make contact 2. Compressor exhaust sensor is open-circuit or short-circuit 3. Outdoor unit PCB is defective 	<ol style="list-style-type: none"> 1. Reconnect the connector according to the wiring diagram 2. Replace the compressor exhaust temperature sensor 3. Replace the outdoor unit PCB
13x	Outdoor ambient temperature sensor	<ol style="list-style-type: none"> 1. The connector is disconnected or does not make contact 2. Outdoor ambient temperature sensor is open-circuit or short-circuit 3. Outdoor unit PCB is defective 	<ol style="list-style-type: none"> 1. Reconnect the connector according to the wiring diagram 2. Replace the outdoor ambient temperature sensor 3. Replace the outdoor unit PCB
14x	Outdoor unit overheating/overcurrent protection	<ol style="list-style-type: none"> 1. System pressure is uneven 2. Outdoor unit is poorly ventilated 3. Condenser is too dirty 4. Outdoor fan or blower capacitor failure 5. Outdoor temperature is too high 6. Outdoor unit PCB or module PCB is defective 7. Compressor failure 	<ol style="list-style-type: none"> 1. Try to start the system 3 times (wait for at least 3 minutes every time). If the problem occurs every time, check the compressor for blockage. 2. Improve the ventilation of the outdoor unit 3. Clean the condenser 4. Replace the outdoor fan or blower capacitor 5. Improve the ventilation of the outdoor unit 6. Replace the outdoor unit PCB 7. Replace the compressor

	status	probable cause	action
15x	Compressor (exhaust) temperature is too high	<ol style="list-style-type: none"> 1. Outdoor unit is poorly ventilated 2. Condenser is too dirty 3. Outdoor fan or blower capacitor failure 4. The refrigerant pressure in the system is too low 5. Outdoor temperature is too high 6. Outdoor compressor exhaust temperature sensor is open-circuit or short-circuit 7. Outdoor unit PCB is defective 	<ol style="list-style-type: none"> 1. Improve the ventilation conditions 2. Clean the condenser 3. Replace the outdoor fan or blower capacitor 4. Check the system pressure. If pressure is too low, check the system for leakage. If there is no leakage, refill the system 5. Improve the ventilation conditions 6. Replace the outdoor compressor exhaust temperature sensor 7. Replace the outdoor unit PCB
16x	Outdoor coil high temperature protection	<ol style="list-style-type: none"> 1. Outdoor unit is poorly ventilated 2. Condenser is too dirty 3. Outdoor fan or blower capacitor failure 4. Outdoor temperature is too high 5. Outdoor coil sensor failure 6. Outdoor unit PCB is defective 	<ol style="list-style-type: none"> 1. Improve the ventilation conditions 2. Clean the condenser 3. Replace the outdoor fan or blower capacitor 4. Improve the ventilation conditions 5. Replace the outdoor coil sensor 6. Replace the outdoor unit PCB



Printed on recycled paper